

yuwell

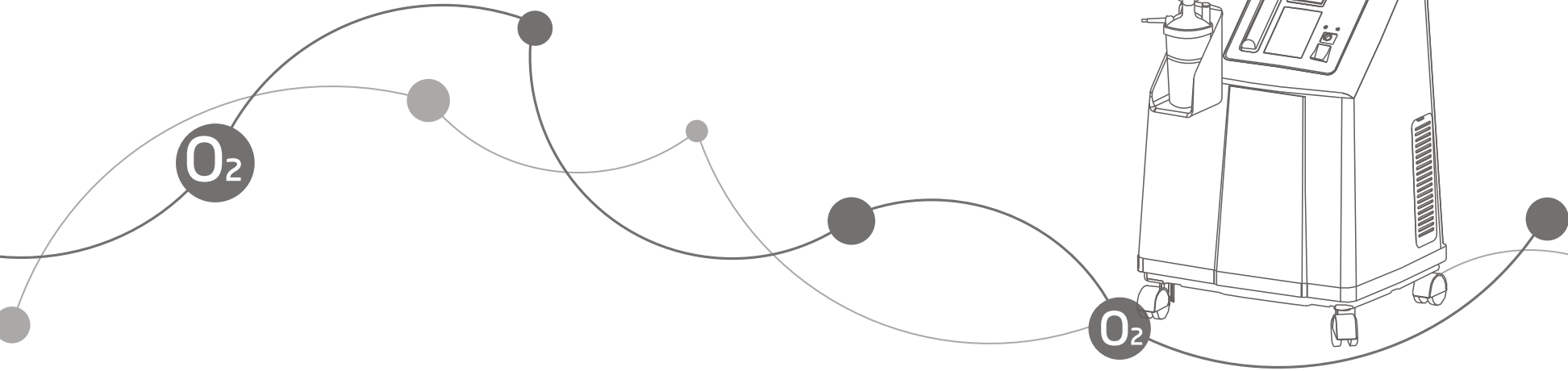

7F-5/8/10(W) Oxygen Concentrator

User's Manual

JIANGSU YUYUE MEDICAL EQUIPMENT & SUPPLY CO., LTD.
Sales Center Address: Huanyuan East Road No.1, Xuzhuang Software Park,
Nanjing, Jiangsu Province, P.R. China, 210000
Manufacturing Address: YunYang Industrial Park, DanYang, Jiangsu Province,
P.R. China, 212300
<http://www.yuwell.com>

Please read the user's manual closely before using!

TABLE OF CONTENTS

SAFETY NOTES-----	1-4
FEATURES-----	5-7
HANDLING-----	8-8
OPERATING & INSTALLATION-----	9-12
MAINTENANCE-----	13-15
TROUBLE SHOOTING GUIDE -----	16-18
DISASSEMBLY-----	19-21
OTHER ATTENTION ITEMS-----	22-23

WARNING: For avoiding power outage or oxygen concentrator operating failure, exigent oxygen user and serious patient must equip with reserve oxygen supply (for example: oxygen cylinder, oxygen bag). This device must equip with reserved oxygen supply and is not used as life supporting or life sustaining.

BEFORE INSTALLATION

- › The concentrator should always be kept in the upright to prevent cabinet damage when transporting.
- › When the electrical source, power voltage is beyond the normal power voltage range. Please add voltage stabilizer.
- › Use eligible, safe power set and junction box.
- › Only the technician can open the oxygen concentrator's cabinet.

STORGE PLACE

- › You may select the most suitable room when using your oxygen concentrator. Use the casters to transfer the concentrator from room to room.
- › Place the unit away from all sides for at least 10cm (4inches) from walls, draperies, furniture, or other obstruction. Do not place the unit in a confined area.

SAFETY NOTES

- ▶ Oxygen concentrator must avoid from heat, fire, moisture, exorbitant or over-low extream condition.
- ▶ Sundries and vessel should not be placed on top of the concentrator.
- ▶ NEVER block the air inlet of the unit or place it on a soft surface, such as a bed or couch, where the air inlet may be blocked. Keep the inlet free from lint, hair, etc.

USING

- ▶ The use of oxygen therapy requires that special attention to reduce the risk of fire. Users **MUST NOT SMOKE** while using this device. Keep all matches, lighted cigarettes or other sources of ignition out of the room in which this product is located. **NO SMOKING** signs should be prominently displayed. Textiles and other materials that normally would not burn are easily ignited and burn with great intensity in oxygen enriched air. Failure to observe this warning can result in severe fire, property damage and cause physical injury or **DEATH**.
- ▶ For optimum performance, do not open or turn off the concentrator frequently, reset after 3~ 5 minutes. Shorter periods of operation may reduce maximum product life.
- ▶ A spontaneous and violent ignition may occur if oil, grease or greasy substances come in contact with oxygen under pressure. These substances **MUST** be kept away from the oxygen concentrator, tubing and connections, and all other oxygen equipment. **DO NOT** use any lubricants unless recommended by manufacturer.

SAFETY NOTES

MAINTENANCE

Only the authorized or trained technician can perform the maintenance or adjustments to the oxygen concentrator. The manufacturer recommands each operation time shoud not be less than 30 mininutes, do not frequently press the switch in order to extend the operation life to the machine.

RADIO FREQUENCY INTERFERENCE

Most electronic equipment is influenced by Radio Frequency Interference (RFI). **CAUTION** should be exercised with regard to the use of portable communications equipment in the area around such equipment.

TO REDUCE THE RISK OF BURNS, ELECTROCUTION, FIRE OR INJURY TO PERSONS

- ▶ Avoid using while bathing. If continuous usage is required by the doctor's prescription:
The concentrator must be located in another room at least 2.5m away from the bath.
- ▶ Do not come in contact with the concentrator while wet.
- ▶ Do not place or store product where it can drop into water or other liquid.

SAFETY NOTES

- ▶ DO NOT contact the product that has fallen into water. Unplug immediately.
- ▶ A product should never be left unattended when plugged in.
- ▶ This device is to be used only in accordance with the prescription of a doctor and this user's manual. If at any time the patient or attendant conclude that the patient is receiving an insufficient amount of oxygen, the supplier and/or doctor should be contacted immediately. No adjustments should be made to the flowrate unless prescribed by a doctor.
- ▶ Close supervision is necessary when this product is used near children or individuals with disability.
- ▶ Use this product for only intended use as described in this manual.
- ▶ Do not use parts, accessories or adapters other than those authorized by manufacturer.
- ▶ Do not connect the concentrator with other oxygen concentrators or oxygen therapy devices.
- ▶ Use of some administration accessories or certain humidifiers not specified for use with oxygen concentrator may impair the performance.
- ▶ In certain circumstances oxygen therapy can be hazardous. Manufacturer recommends that you seek medical advice before using this product.
- ▶ Avoid creation of any spark near medical oxygen equipment. This includes sparks from static electricity created by any type of friction.

FEATURES

SUMMARY

The function of oxygen

- ▶ Supplying oxygen to patients can assist in the treatment of heart head blood-vessel, respiratory system, such as chronic obstructive pneumonia disease, rehabilitation and hypoxia conditions.
- ▶ Oxygen could improve body function, especially suit for elderly, pregnant women, physique, students etc. Who got physiological hypoxia. It may also reduce fatigue after heavy manual or mental consumption.

THE SCOPE OF PRODUCTS

For hospital and homecare to supply oxygen to patients.

STRUCTURE

- ▶ The product is mainly composed of oxygen making host, flow meter, humidifier.
- ▶ Safety plastic shell.
- ▶ With time collect function: Display the operation time in LCD.
- ▶ High and low pressure alarm function.
- ▶ Power loss alarm function.
- ▶ The compressor with thermal protector guarantee better security.
- ▶ *With nebulizer function. (7F-5W, 7F-8W, 7F-10W)

FEATURES

SPECIFICATIONS

1. Maximum recommended flow:
7F-5(W): 5L/min, 7F-8(W): 8L/min, 7F-10(W): 10L/min
2. Flow Range:
7F-5(W): 0.5 ~ 5L/min, 7F-8(W): 0.5 ~ 8L/min, 7F-10(W): 0.5 ~ 10L/min,
3. Change in maximum recommended flow when back pressure of 7kPa is applied: < 0.5L/min
4. Oxygen Concentration: 95.5% ~ 87%
5. Maximum Outlet Pressure:
7F-5/8(W): 45kPa ± 4.5kPa(6.52psi ± 0.65psi),
7F-10(W): 62kPa ± 4.5kPa(8.99psi ± 0.65psi),
6. Pressure Relief Mechanism Operational at:
250kPa ± 25kPa (36.25psi ± 3.63psi)
7. Noise: 7F-5(W) ≤ 53dB(A), 7F-8(W) ≤ 55dB(A), 7F-10(W) ≤ 60dB(A),
8. Maximum Nebulization Rate: ≥ 0.2mL/min(7F-5/8/10W)
9. Power Supply:
 AC120V ± 10% AC220V ± 10% AC230V ± 10%
 50Hz 60Hz 1.5 amps(AC220V~240V) ; 3.0 amps(AC120V)
10. Input Power: 7F-5/8(W): 500VA, 7F-10(W): 850VA
11. Weight: 7F-5(W): 27kg, 7F-8(W): 28.5kg, 7F-10(W): 33kg
12. Dimension: H44.5cm (17.5") x W37.2cm (14.7") x D68cm (26.8")
13. Minimum operating time: 30minutes
14. Altitude: Up to 1828 meters (6000 ft) above sea level without degradation of concentration levels. From 1828 meters (6000 ft) to 4000meters (13129 ft) below 90% efficiency.
15. Safety system:
Current overload or loose connection, automatic shutdown.
Compressor with abnormal high temperature, automatic shutdown.
High & low pressure alarm function, automatic shutdown.
Compressor error function, automatic shutdown. Low oxygen concentration alarm function.

FEATURES

16. Minimum Operating Time: 30minutes
17. Electric classification: Class II , type BF application part
18. Work system: work continuously.
19. NORMAL OPERATION CONDITIONS:
Temperature range: 10°C ~ 35°C (50°F ~ 95°F);
Relative humidity: 30% ~ 75%;
Atmosphere pressure: 860hPa ~ 1060hPa(12.47psi ~ 15.37psi);
NOTE: When storage temperature is below 5°C, please keep the equipment in normal working condition for at least 4 hours before using.
20. Temperature at oxygen outlet: ≤ 46°C
21. Suggestion: The length of nasal oxygen cannula should be less than 15.2 meters and should not be pinched.
22. Transportation and storage conditions:
Temperature range: -20°C ~ +60°C(-68°F ~ +140°F),
Relative humidity: 10% ~ 93%, no condensation,
Atmosphere pressure: 700hPa ~ 1060hPa(10.15psi ~ 15.37psi).
NOTE: Oxygen concentrator should be stored with out intense sunlight, no corrosive gas and in a well ventilated room, avoid jolt and inverted recumbent transport.

HANDLING

UNPACKING

⚠ NOTE: Unless the oxygen concentrator is to be used immediately, otherwise it should be stored in the containers until it's being used again.

- ▶ Check for any obvious damage to the carton or its contents. If damage is evident, please notify the carrier or local dealer.
- ▶ Remove all loose packing from the carton.
- ▶ Carefully remove all the components from the carton.

INSPECTION

- ▶ Examine exterior of the oxygen concentrator for nicks, dents, scratches or other damages. Inspect all components.

STORAGE

- ▶ Store the repackaged oxygen concentrator in a dry area.
- ▶ Do not place other objects on top of the repackaged concentrator.

OPERATING & INSTALLATION

FEATURE VIEW



Figure 1: view of the machine

OPERATING & INSTALLATION



Figure 2: view of the humidifier

PREPARE WORK

- ▶ Unscrew the bottle from the humidifier counter-clockwise. Fill the bottle with pure water (or distilled water) to the level indicated by the manufacturer.
- ▶ Screw securely to the bottle back clockwise.
- ▶ Plug in: First confirm the power switch of oxygen concentrator is off, then connect the plug.
- ▶ Do not use extended power line.

OXYGEN ABSORBING OPERATION

- ▶ Turn the power switch to " | ", the LCD shows "HELLO", green, yellow, red indicator all light indicates that the machine is normal. The green indicator lights only 1 second later, 4 seconds later, the LCD shows elapsed time, then the machine goes to normal operation.

OPERATING & INSTALLATION

- ▶ Turn the flowrate knob to require oxygen need (Reed as centre of the black ball). Turn the knob anticlockwise to increase the flowrate, and clockwise to decrease. Meanwhile, humidifier bottle will have air bubble around the sieve core. Then, oxygen comes from the oxygen outlet. (Figure 3)
- ▶ Connect the nasal oxygen cannula to the oxygen outlet of the humidifier, the other end match the patient.

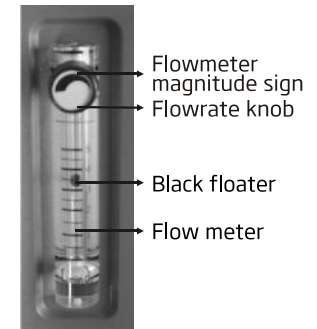

Figure 3

- ⚠ Note: Adjust the time of absorbing oxygen and the flowrate range according to the doctor's advices.
- ▶ If the humidifier makes continuous sound, it shows that the nasal oxygen cannula jammed, then please clear the pipeline.
- ▶ CAUTION: If the flowrate on the flowmeter ever falls below 0.5L/min, check tubing or accessories for blocked or kinked tubing or a defective humidifier bottle.

*NEBULIZING OPERATION(7F-5/8/10W)

- ▶ Fill proper medicinal liquid in the nebulizing cup (Please follow the doctor's advices for nebulizing time or don't exceed the maximum scale of the nebulizing cup).
- ▶ Upward pull out the nebulizing cover on the nebulizing interface. (Figure 4)

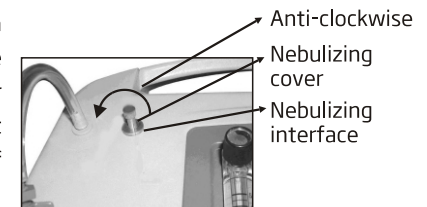

Figure 4

OPERATING & INSTALLATION

- ▶ Connect the air hose to nebulizing cup and nebulizing interface, then turn on the power of the oxygen concentrator, now can begin nebulizing cure immediately.
- ▶ NOTE: the time for nebulizing should follow the doctor's advices.
- ▶ When nebulizing completing, please turn the nebulizing cover right to nebulizing interface for tightening. When the treatment finishes, please turn off the oxygen concentrator.
- ▶ Screw the nubilizing cover when finished.

TURNING OFF

- ▶ Take off nasal oxygen cannula from oxygen outlet first, close power switch, and then cut off power source.

SYMBOLS

Symbol	Description	Symbol	Description
~	Alternating current	⚠	Consult the manual
□	Class II Equipment	⚠	Type BF application part
○	OFF(power, disconnection from the mains)		ON(power, connection to the mains)
○	OFF(for part of equipment)	⊙	ON (for part of equipment)
🚫	NO SMOKING	↑↑	KEEP UP
🍷	FRAGILE	☂	KEEP DRY

MAINTENANCE

- ⚠ WARNING: CUT OFF the power supply first. To avoid electrical shock, DO NOT removes cabinet.

CLEANING CABINET

- ▶ Clean the cabinet with a mild household cleaner and non-abrasive cloth or sponge at least one time each month.

CLEANING OR REPLACING FILTERS

Please clean and replace the filters in time, it's very important to protect compressor and delay machine's life.

- ⚠ CAUTION: DO NOT operate the concentrator without the filters installed.

- ▶ Clean the I-stage filter once half a month. I -stage filter can be taken out of the foreside panel. (Figure 5)



The I-stage filter is in the both side of the machine, you can pull out it directly.

Figure 5

MAINTENANCE

- Replace the II-stage filter once a month.

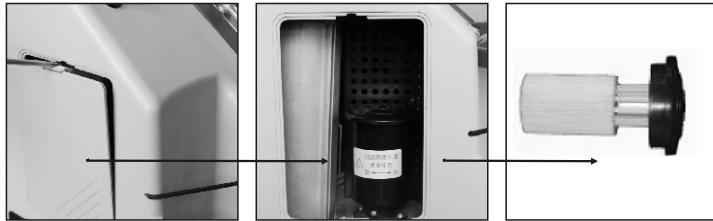

Figure 6

Figure 7

Figure 8

1. Open filter access door.(Figure 6)
2. Unscrew the filter corn.(Figure 7)
3. The frequency for replacing the II-stage filter mesh depends on practically using and condition. If the filter core turns black, please replace it at once, no matter how long it used.(Figure 8)

CLEANING HUMIDIFIER

- Change the water in humidifier bottle every day.
- Clean humidifier once a week with soapy water and rinse it with a solution of water and vinegar(10:1). Rinse thoroughly with warm water and refill with pure water (or distilled water) to the level shown on the humidifier. (NOTE: No blobs in oxygen tubing)

MAINTENANCE

*CLEANING NEBULIZING assembly(7F-5/8/10W)

- Clean the nebulizing assembly after using each time.
- Pull out the air hose, pull the mouthpiece, downward pull the nebulizing cup's cap, empty remained medicinal liquid in the nebulizing cup, then wash the air hose, mouthpiece, nebulizing cup's cap, nebulizing baffle, nebulizing cup, ripple tube, T-piece, etc , with pure water or immerge them in warm water for about 15 minutes(Figure 9). In order to wash them properly, you may add some vinegar in water.
- ⊗ NOTE: DO NOT cook the accessories above for wash or wash them with boiled water, in case they'll distort when heating.
- After finishing washing you must dry all the accessories before storing.

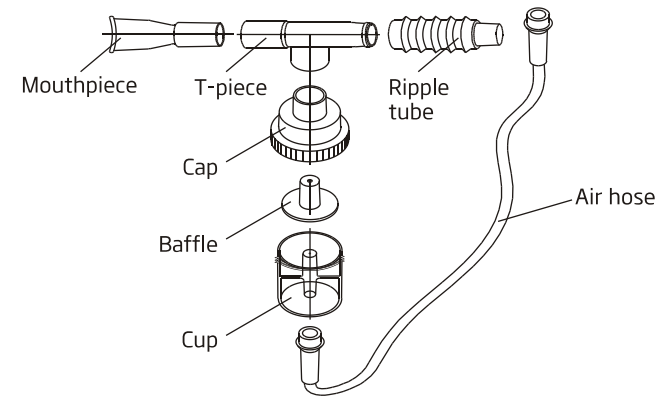

Figure 9

TROUBLE SHOOTING GUIDE

Symptom	Probable reasons	Solution	Remark
Press the switch, the concentrator is alarm of continuous buzzer but no display and working.	1)Power cord NOT plugged in	1)Insert plug into outlet	Repairs by qualified personnel
	2)No power at outlet	2)Use normal power	
	3)The power is no sufficient at outlet	3)Do not use extended cord	
	4)Raise circuit breaker	4)Press it	
	5)If this state continues, stop using the concentrator and get in touch with the supplier at once.		
Concentrator is running, elapsed time meter displays, but the green light illuminate and the yellow light blinks, the concentrator makes continuous sound.	1)Output voltage is not enough	1)Don't use extension cords. Replace a power supply	Repairs by qualified personnel
	2)I-stage filter blocked	2)Replace or clean it	
	3)II-stage filter blocked	3)Replace or clean it	
	4)The air intake of compressor kinked	4)Open the cabinet smooth and clean them	
	5)Pressure relief valve of compressor leaked gas	5)Repair or replace valve	
	6)Outlet air of the compressor is not enough	6)Replace it	
	7)Tube on the sieve bed leaked gas	7)Tighten it	
	8)Insufficient air exchanging of regulator	8)Replace it	
	9)Failure of main controlling PC board	9)Replace it	
Elapsed time meter displays, the green and the yellow light illuminate, but the oxygen concentrator stops running immediately and makes continuous sound.	1)Four corns plug-in of the valve has not been inserted completely	1)Check and connect the circuit board to the valve's four corns plug-in	
	2)Air hose jammed	2)Replace it	
	3)Can't open the valve	3)Replace it	
	4)Failure of the main electronic control circuit board	4)Replace it	

TROUBLE SHOOTING GUIDE

Symptom	Probable reasons	Solution	Remark	
Concentrator is running with no abnormal sound and elapsed time meter displays, the green light illuminate, the yellow light is duck, but makes no or little oxygen.	Flowmeter displays "0" or is on the low side, has not been regulated	1)Flowmeter closed or valve on the low side	1)Reregulate the flowmeter to the prescribed value	
	Flowmeter displays and can be regulated	1)Safety valve of the humidifier cover open	1)Reset it	
		2)Air leak between the humidifier bottle and cover	2)Tighten the bottle and cover or replace them	
		3)Nasal oxygen cannula has fault	3)Replace it	
		4)Oxygen outlet pipeline of the flowmeter loose	4)Tighten the flowmeter pipeline	Repairs by qualified personnel
	Flowmeter only can be turned lower at some valve but can't turn higher	1)Nasal oxygen cannula kinked or blocked	1)Sort out the pipeline	
		2)Filter in the humidifier bottle blocked	2)Clean or replace it	
		3)Linked pipeline between flowmeter and oxygen outlet kinked or blocked	3)Sort out the pipeline	Repairs by qualified personnel
	Flowmeter displays "0", has no response after regulating	1)Air inlet pipeline of the Flowmeter loose	1)Tighten the flowmeter pipeline	Repairs by qualified personnel
		2)Flowmeter failure	2)Replace it	
3)Depress valve broken or no air out		3)Replace it		

TROUBLE SHOOTING GUIDE

Symptom	Probable reasons	Solution	Remark
The nasal cannula has more mirage or blobs	1)It's not ventilate completely around machine, so operating temperature is too high	1)Make sure the machine is at least 10cm away from the walls, other jam or heater	
	2)Temperature of the water added in humidifier bottle is overhigh	2)Add cold water in bottle, but don't add overhot water	
	3)The water added in humidifier bottle is too much	3)Make sure the water stays between the maximum and minimum of the water scale	
	4)The machine stops suddenly during breathing oxygen	4)Stop breathing oxygen immediately. Restart the machine to eject the hydrosphere	
	5)The machine stops suddenly when folding the nasal cannula	5)Smooth the nasal cannula	
	6)Fan inside the machine can't run or running rate turns slow make the operating temperature overhigh	6)a.Take out the eyewinker that lock the fan 6)b. Replace it	Repairs by qualified personnel
※ The nebulizer doesn't run	1)Check nebulizer is distortional or not if it was disinfected.	1)Replace it	
	2)Check the air hose whether it is bended or not	2)Ensure that it isn't bended and airflow is flowed smoothly when it is used	
	3)Check whether medication was used up or not	3)Add appropriate amount medicine to cup	
	4)Check the nebulizer is fixed properly or not	4)Fix it according the method of nebulizer's fixing	
※ Water drops have formed on the air hose	The medication was over-filled or the nebulizer was washed	Add appropriate amount medication to cup. Connect air hose to main body and turn on. Close and open repeatedly by finger in order to get out the water drops.	

⚠ If you have all other problems, TURN OFF the concentrator first, use your reserve oxygen supply (if provided) and contact dealer or manufacturer immediately.

DISASSEMBLY (CUT OFF the power supply first)

Cut off the power supply first

- ▶ Turn the power switch to the "0" position and unplug it.

DISASSEMBLE THE TOP COVER

- ▶ Unscrew 8 fixing screws on four sides of the machine. (Figure 10)

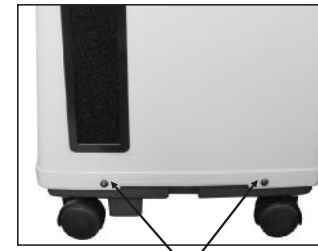

Screws

Figure 10

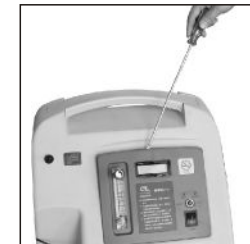

Figure 11

DISASSEMBLE THE PANEL

- ▶ Prise the panel with a screwdriver . (Figure 11)
- ▶ Pull off the tube which connects with the oxygen outlet, then take out the panel. (Figure 12)



connecting tube

Figure 12

DISASSEMBLY (CUT OFF the power supply first)

DISASSEMBLE THE CABINET

- ▶ Lift the panel up. (Figure 13)



Figure 13

- ▶ Unscrew the fixing screws at both sides of the panel(each 7), remove the side panels. (Figure 14)

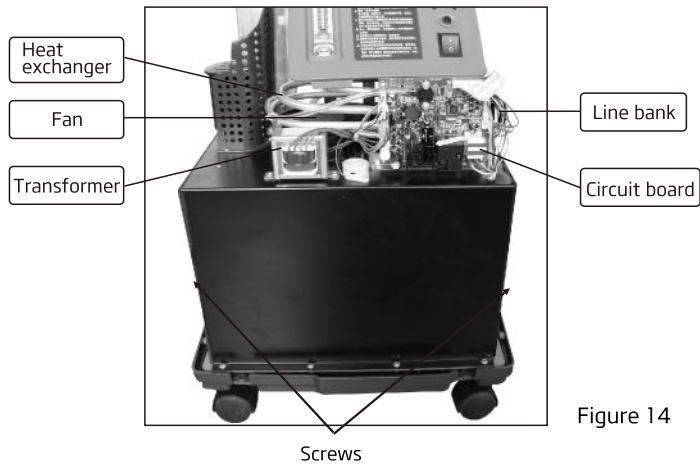

Figure 14

DISASSEMBLY (CUT OFF the power supply first)

Dismantled figures: (Figure15, Figure 16)

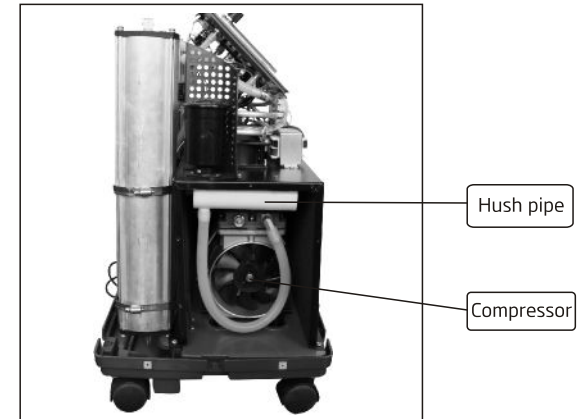

Figure 15

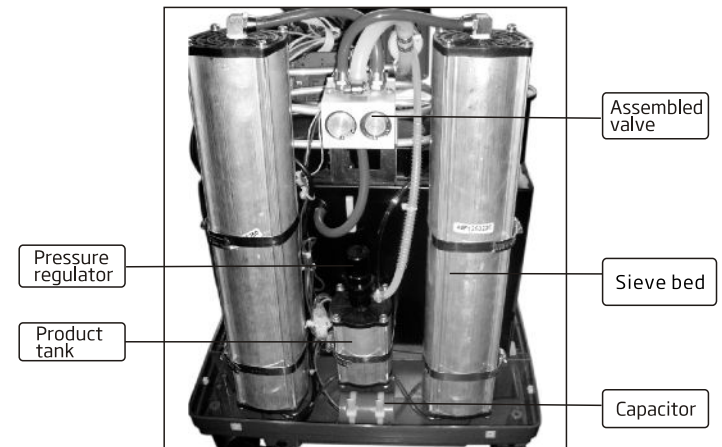
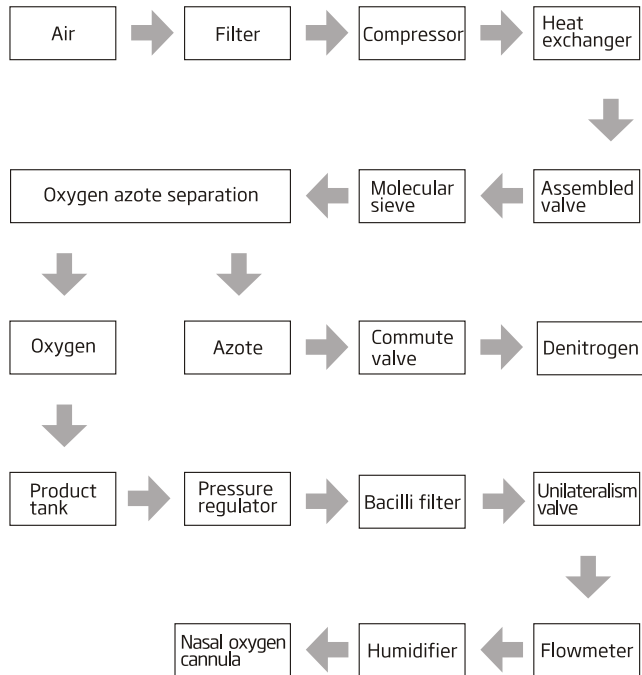

Figure 16

OTHER ATTENTION ITEMS

GAS PASS OPERATION SKETCH MAP:



OTHER ATTENTION ITEMS

ELECTRICAL RATIONALE

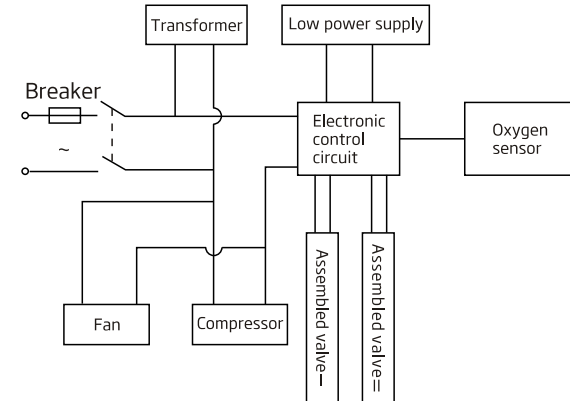

ACCESSORIES LIST

1. Nasal oxygen cannula	1 set
2. User's manual	1 piece
3. Filter core	1 set
*4. Nebulizer(7F-5/8/10W)	1 set

All specifications and product configurations are subject to change without notification.